



# Supercast SW

## Swellable waterstops for in-situ concrete

### Uses

Integral sealing for construction joints precast concrete and cast in-situ.

Convenient and problem solving in situations where a conventional waterstop would require complex shuttering.

Typical uses include secant piled and diaphragm walled basements, pile caps and casting against old concrete. The Supercast SW range can provide simple solutions to detailing pipe entries, construction joints in the vertical plane and to kicker joints.

They can be linked to Supercast PVC waterstops to give an appropriate effective combination of waterstops which maintain network continuity.

### Advantages

- Easy to install by adhesive bonding, or casting into joint faces
- Supercast SWX enables full integration of Supercast SW and Supercast PVC networks.
- Supercast SW Adhesive can be applied to damp substrates
- Solves detailing problems in conjunction with Supercast PVC waterstops
- Swelling properties unaffected by long term wet / dry cycling
- Tolerant of salts in concrete and groundwater
- Sustains effective seal in wet conditions
- Highly adaptable to accommodate complex joint shapes

### Description

The Supercast SW range consists of swellable waterstops; Supercast SW formed sections, Supercast SWX gun-applied paste and Supercast SW adhesive.

Supercast SW sections are made from high performance synthetic elastomer strips. The swelling action of the Supercast SW range is the result of contact between water and hydrophilic groups which are an intimate part of the Supercast SW polymeric structure. These hydrophilic groups are not subject to extraction and loss of swelling performance by prolonged or repeated wetting.

Expansion of the waterstop creates a positive pressure against the faces of the concrete joint, thus preventing water passing through the joint.

Supercast SWX is a grey, elastomeric water-swellable gun applied paste. Supercast SWX can be used as a swellable adhesive to adhere Supercast SW waterstop to concrete. It has the capability to fill undulations and surface holes in the concrete beneath the waterstop and swell into these when required.

Supercast SWX also enables Supercast SW sections to be linked into conventional Supercast PVC waterstop networks. This allows the use of Supercast PVC for expansion joints and Supercast SW for construction joints whilst maintaining an integrated waterproofing network.

### Design criteria

Supercast SW should be used to prevent the passage of water through non-movement joints in both new in-situ concrete and between new and existing concrete. Supercast SW increases in volume up to 300% and gives resistance to hydraulic pressure.

Swelling of Supercast SW in fresh concrete is minimal therefore maximising the positive pressure seal provided by the hydrophilic to the protected joint.

Supercast SW 20 has a larger section and so offers a greater surface area of contact to the concrete in areas of higher risk, such as when waterproofing Grade 3 and Grade 4 basements.

Both Supercast SW10 and SW20 have a delayed swell action which helps prevent pre-swell during wet site conditions (see limitations).

The minimum thickness of concrete cover required to accommodate pressure developed during the swelling process is 75 mm for Supercast SW10 and 80mm for SW20.

### Standard Compliance

Supercast SW 10 and Supercast SW 20 are suitable for use in contact with potable water and are Water Regulations Advisory Service approved products.

# Supercast SW

## Specification clauses

### Supercast SW

Water swellable polymeric hydrophilic waterstops (and attachments) where shown on the drawings, shall be Fosroc Supercast SW10 (or SW20) obtained from Fosroc. It shall be used in accordance with the manufacturer's current application instructions.

Water swellable polymeric hydrophilic waterstops, where shown on the drawings, shall be made from a preformed elastomeric strip which can integrate into existing waterstop networks. It shall be free from rubber, bentonite or other inclusions. The waterstop shall have an unrestrained volumetric expansion of up to 300%. It must not deteriorate under prolonged wet / dry cycling. It must be able to withstand a hydrostatic head of up to 50 metres (refer SW grade). It shall be used in accordance with the methods given in the manufacturer's current data sheet.

## Typical Properties

<b>Form:</b>	<b>Rectangular section elastomeric strips</b>
<b>Size:</b>	
<b>Supercast SW10:</b>	5 mm x 20 mm
<b>Supercast SW20:</b>	10 mm x 20 mm
<b>Solids content:</b>	100%
<b>Colour:</b>	
<b>Supercast SW10:</b>	Black
<b>Supercast SW20:</b>	Red
<b>Unrestrained volumetric expansion ratio:</b>	Up to 300%
<b>Application temperature range:</b>	-5° to 50°C
<b>Service temperature range:</b>	-30° to 70°C
<b>Hydrostatic pressure resistance:</b>	
<b>Supercast SW10:</b>	30 metres
<b>Supercast SW20:</b>	50 metres

\*(In concrete construction joint with no movement)

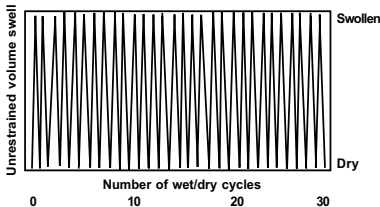

Graphic showing reproducibility of volume swell with wet/dry cycling

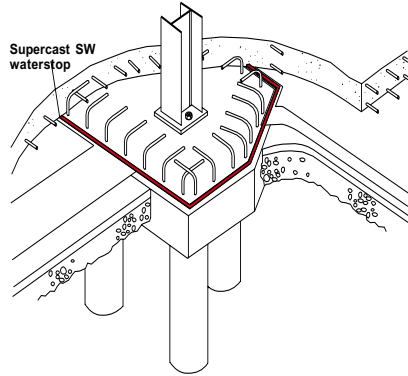

Pile cap detail using Supercast SW waterstop

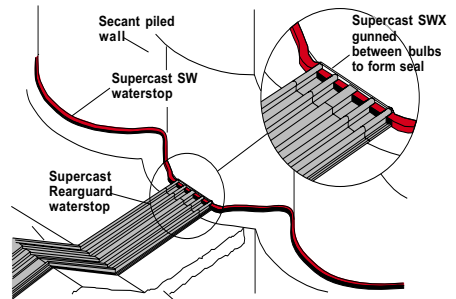

Supercast SW, Supercast SWX and Supercast Rearguard waterstops at secant pile wall and floor slab junction

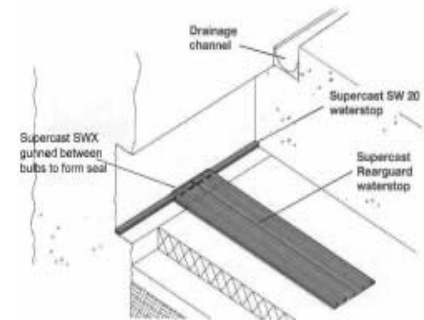

Diaphragm wall to floor slab detail using Supercast SW20 and Supercast Rearguard 'R' waterstops.

# Supercast SW

## Application instructions

Supercast SW may be positioned by bonding with Supercast SWX or Supercast SW Adhesive. The waterstop may be installed either into a groove cast in the concrete or directly onto the concrete surface.

## Estimating

### Pack sizes

**Supercast SW10:** 5 mm x 20 mm x 15 metre rolls

**Supercast SW 20:** 10 mm x 20 mm x 5 metre rolls  
10 rolls per carton

**Supercast SWX:** 310 ml cartridge packed in cartons of 20, or as a single tube

### Supercast SW

**Adhesive:** 380 ml cartridge packed in cartons of 20

## Coverage

**Supercast SW 10/SW 20:** Usually single run of strip per joint

### Supercast SW Adhesive:

- 6 mm diameter bead (per cartridge) - 13.5 metres run

- 12 mm diameter - 3.4 metres

The above coverages are approximate and make no allowance for wastage.

**Note:** In accordance with Commercial or Health & Safety requirements packaging detail may alter. Please contact your local Fosroc office for detail.

## Limitations

Supercast SW should not be used for expansion joints or those subject to movements in excess of 2mm.

Supercast SW should not be used in locations which allow free unrestrained swelling or for free standing walls, such as bund or dwarf walls, where the swell pressure is sufficient to lift the wall from its foundations. Supercast PVC or SWX of minimum bead diameter 12 mm, should be preferred, dependent on the degree of seal required.

Supercast SW must not be immersed in water prior to concrete placement, however, Supercast SW20 can tolerate upto 3 days exposure to damp conditions on site.

See diagram opposite.

## SW Details with 2 cages of reinforcement

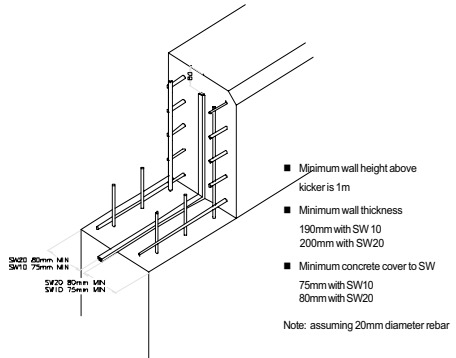

## SW Details with 1 cage of reinforcement placed centrally

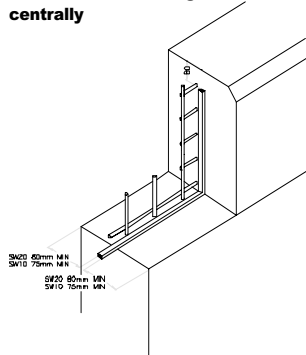

## Storage

### Supercast SW

**Shelf life:** 12 months

Store in original unopened cartons or bags in cool, dry conditions, away from sunlight.

### Supercast SWX

**Shelf life:** 9 months

Store in original unopened cartridges or cartons in cool, dry conditions, away from sunlight.

### Supercast SWX Adhesive

**Shelf life:** 12 months

Store in original unopened cartridges or cartons in cool, dry conditions, away from sunlight.



# Supercast SW

---

## Precautions

### Health and safety

#### Supercast SW

There are no known health hazards associated with Supercast SW10 and SW20 in normal use.

#### Supercast SWX

Supercast SWX may cause sensitisation by skin contact. Avoid contact with skin and eyes. Wear suitable gloves and eye/face protection. Use only in well ventilated areas.

#### Supercast SW Adhesive

No significant hazard. For additional information see relevant product safety data sheet.

## Additional information

### Ancillary materials

#### Supercast SWX

---

<b>Form:</b>	Elastomeric water swellable paste
--------------	-----------------------------------

---

<b>Colour:</b>	Grey
----------------	------

---

<b>Tack-free time:</b>	Approximately 1 hour (20°C / 50% RH)
------------------------	---

---

<b>Cure rate:</b>	3 mm in 24 hours
-------------------	------------------

---

<b>Volume swell ratio:</b>	200%
----------------------------	------

---

<b>Concrete pour:</b>	2 to 8 hours
-----------------------	--------------

---

#### Supercast SW Adhesive

---

<b>Form:</b>	Grey paste
--------------	------------

---

<b>Application temperature:</b>	5°C to 30°C
---------------------------------	-------------

---

<b>Maximum open time:</b>	30 minutes
---------------------------	------------

---

<b>Concrete pour:</b>	2 to 8 hours
-----------------------	--------------

---

**Adhesion:** Can be used on damp concrete provided it is rag dry.

The above data represents typical values and should not be considered as a purchase specification.

Supercast is the trademark of Fosroc International Ltd.



## Fosroc Hong Kong Ltd.

2001-5A, Pacific Plaza  
410 Des Voeux Road West  
Hong Kong

Tel: +852 2882 8662

Fax: +852 2895 2931

Email: [hongkong@fosroc.com](mailto:hongkong@fosroc.com)

**[www.fosroc.com](http://www.fosroc.com)**

For Macao & Taiwan, please  
contact Fosroc Hong Kong office.

## Important note

Fosroc products are guaranteed against defective materials and manufacture and are sold subject to its standard Conditions for the Supply of Goods and Services, copies of which may be obtained on request. Whilst Fosroc endeavours to ensure that any advice, recommendation, specification or information it may give is accurate and correct, it cannot, because it has no direct or continuous control over where or how its products are applied, accept any liability either directly or indirectly arising from the use of its products, whether or not in accordance with any advice, specification, recommendation or information given by it.

---

## SALES REPRESENTATIONS IN MAINLAND CHINA

Beijing · Changchun · Chengdu · Chongqing · Guangzhou · Shanghai · Shenzhen · Tianjin · Wuhan · Xiamen

For enquiries, please contact Fosroc Guangzhou office.

### Fosroc Guangzhou Limited

No. 7 Hong Yuan Road, Eastern Section, Guangzhou Economic & Technological Development District, Guangzhou, P.R.C. Post Code: 510760

Tel: +86 (20) 8226 9245

Fax: +86 (20) 8226 8010

email: [china@fosroc.com](mailto:china@fosroc.com)