

## Mix and place polyester resin anchoring grouts

### Uses

High strength corrosion resistant heavy duty anchoring. These anchors include bolts, tendons or dowels in drilled or formed holes located in concrete masonry, brickwork or natural rock.

Permanent installation of reinforcement starter bars, foundation bolts, ballustrading, barriers and safety fences, railway tracks, ground anchors for towers, cranes, dock sills.

### Advantages

- Ultra rapid strength gain
- Vibration resistant
- Corrosion resistant
- May be applied under damp or wet conditions
- Can be placed underwater
- Non expansive
- Pre-weighed components ensure consistent performance of the grout

This type of installation is a permanent fixing.

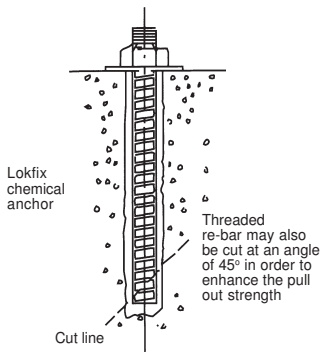

Figure 1: Threaded rebar with Lokfix chemical anchor

### Technical support

Fosroc offers comprehensive technical support, including help at the design stage, application advice and on site problem solving. Specifiers and contractors are encouraged to contact our trained staff for answers to their questions.

For further information please contact us at your nearest Fosroc office.

### Description

The Lokfix range consists of pre-measured, two pack, filled polyester resin grouts. The two components are polyester resin and a catalysed filler. The range comprises three standard versions.

Lokfix S80 and P80 are designed for use where annular gaps are up to 25 mm greater than the diameter of the fixing.

Lokfix S80 is designed for vertical downward hole.

This type of installation is semi-permanent.

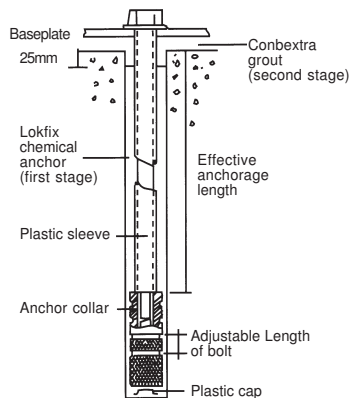

Figure 2: Hexagon headed bolt with removable nut and tie bar with Lokfix chemical anchor

# Lokfix

( Formerly known as Lokset )

Lokfix P80 contains thixotropic chemicals which can allow the product to be pumped into overhead or horizontal holes and should be used for annular gaps of up to 25 mm.

## Design criteria

The version of Lokfix grout to be used will depend upon ambient temperature and anchor conditions.

The high strength of the cured resin permits strong anchors to be created. The ultimate bond strength developed depends upon:

- Strength of host material
- Length of resin bond to bar
- Hole preparation and formation
- Type and dimension of bar

The following formula may be used to determine the minimum depth of installation for Type 1 rebar bolts, to ensure the shear stress within the concrete is kept within the limits set out in BS 8110.

$$\text{Minimum hole depth (mm)} = \frac{0.6Y}{SII d_2} \cdot \frac{II d_1^2}{4} = \frac{0.15Y d_1^2}{S d_2}$$

where Y is characteristic yield strength of steel (generally 460 N/mm<sup>2</sup> for high yield steel bars)

S is permitted shear stress in concrete (N/mm<sup>2</sup>)

d<sub>1</sub> is bar diameter (mm)

d<sub>2</sub> is hole diameter (mm)

This formula is used typically as shown in Table 1.

Table 1

### Minimum hole depth

Characteristic concrete strength (N/mm <sup>2</sup> ):						
Permitted concrete shear stress using Type One Bar (N/mm <sup>2</sup> ):						
Bar diameter (mm)	Yield (tonnes)	Hole diameter (mm)	Minimum hole depth (mm)			
12	5.2	20	280	250	225	200
16	9.3	20	490	445	400	355
20	14.5	25	615	555	500	440
25	22.6	32	750	675	615	540
32	37.0	38	1035	930	845	745
40	57.8	45	1365	1225	1115	980

### Typical Properties

Table 2 - Typical results

Gel time			
Temperature °C:	10°C	20°C	30°C
Minutes:			
Lokfix S80, P80	70	45	30
Compressive strength (N/mm <sup>2</sup> )			
BS 6319 part 2 1983			
1 hour:	42	60	50
3 hours:	75	83	75
24 hours:	95	101	93
7 days:	103	106	102
Tensile strength (N/mm <sup>2</sup> )			
BS 6319 part 7 1985			
3 days:	12	14	11
7 days:	14	14	15
Flexural strength (N/mm <sup>2</sup> )			
BS 6319 part 3 1990			
3 days:	26	25	27
7 days:	33	29	30
Flash point:			
	29°C	29°C	29°C



# Lokfix

( Formerly known as Lokset )

## Specification clauses

### Supplier specification

Mix and place grout where shown on the drawings shall be Lokfix manufactured by Fosroc. It shall be used in accordance with the manufacturer's current application instructions.

### Performance specification

Mix and place grout where shown on the drawings shall be a two component polyester resin system. When fully cured it shall exhibit a compressive strength in excess of 90 N/mm<sup>2</sup>, a flexural strength in excess of 28 N/mm<sup>2</sup> and a tensile strength in excess of 14 N/mm<sup>2</sup> at 7 days.

The storage, handling and placement of the grout must be in strict accordance with the manufacturer's instructions.

## Application instructions

### Hole preparation and formation

Three methods of hole formation are possible.

1. Optimum performance of Lokfix grouts requires rough sided, dust free holes. These can be made by using rotary percussive drills followed by oil-free air or water flushing.
2. Diamond drilled holes should be underreamed.
3. Cast holes should be of inverse dovetail configuration. If parallel sided holes are cast, they should be rough enough to provide an adequate mechanical key.

### Bar preparation

1. All bars should be deformed. This will ensure good bond between bar and grout.
2. They should be degreased and any mill scale or flaky rust removed.

### Mixing

Only a complete pack of resin and catalysed filler should be mixed in one operation. Mixing may be carried out manually or mechanically. When a smooth, even consistency is achieved, the grout is ready for use. It must be placed well within the gel time of the grout.

### Placing

The mixed grout should be poured or pumped steadily into the prepared anchor holes. The anchor bar should then be pressed into the hole to the required depth. Slight agitation of the bar will greatly assist in achieving a complete bond.

The bar should be left undisturbed in the required position until the grout has hardened fully.

### Cleaning

Any mixing drums, pumps etc should be cleaned with suitable solvent within the pot life of the grout.

### Limitations

1. At permanent operating temperatures above 40°C, creep of the cured grout may become significant.
2. Resin anchors should not be used where structural load bearing performances have to be maintained in anchors subjected to fire conditions.
3. For use at temperatures below 5°C, seek advice from Fosroc.

### Estimating

#### Pack sizes

**Lokfix S80, P80:** Can of resin and plastic bag of catalysed filler 1 litre.

#### Volume of Lokfix grout required in ml for each 100 mm of bond length.

(200 mm bond length is the minimum recommended.)

Hole diameter mm	Bolt diameter mm					
	12	16	20	25	32	40
20	25					
25	50	40	25			
32	80	70	60	40		
38	100		100	75	45	
45	150			130	100	45
50	180				150	90
62	280					225

These figures allow for a 25% wastage factor.

If the anchor is in very old concrete, masonry or brickwork the wastage factor should be increased.

**Note:** In accordance with Commercial or Health & Safety requirements packaging detail may alter. Please contact your local Fosroc office for detail.

#### No of bolts/200 mm deep hole which can be fixed using a 1 litre pack of Lokfix

Hole diameter mm	Bolt size mm					
	12	16	20	25	32	40
20	20					
25	10	12	20			
32	6	6	8	12		
38	4		4	6	10	
45	3			3	4	10
50	2		3	3	5	
62	1			1	2	2



# Lokfix

( Formerly known as Lokset )

---

## Storage

### Shelf life

All products have a shelf life of 6 months at 20°C if kept in a dry store in the original, unopened packs.

The shelf life will be reduced at higher ambient temperatures.

### Storage conditions

Store in dry conditions away from high temperatures and high humidity. Keep away from sources of heat and naked flames.

## Precautions

### Health and safety

Lokfix products are flammable. Keep away from sources of ignition - no smoking. In the event of fire extinguish with CO<sub>2</sub> or foam.

Some people are sensitive to resins and solvents. Avoid contact with skin and eyes. Ensure adequate ventilation and avoid inhalation of vapours. Wear suitable protective clothing, gloves and eye/face protection. Barrier creams provide additional skin protection. Should accidental skin contact occur, wash immediately with a resin removing cream, followed by soap and water. In case of contact with eyes, rinse immediately with plenty of water and seek medical advice - do not induce vomiting.

For additional information see relevant Material Safety Data Sheet.

### Additional information

For further details about the use of resin anchoring groups, please contact Fosroc.

Lokfix is the trademark of Fosroc International Limited.

\*Formerly known as Lokset.

**FOSROC**



**Fosroc**

**Hong Kong Ltd.**

2001-5A, Pacific Plaza  
410 Des Voeux Road West  
Hong Kong

Tel: +852 2882 8662

Fax: +852 2895 2931

Email: [hongkong@fosroc.com](mailto:hongkong@fosroc.com)

**[www.fosroc.com](http://www.fosroc.com)**

For Macao & Taiwan, please  
contact Fosroc Hong Kong office.

## Important note

Fosroc products are guaranteed against defective materials and manufacture and are sold subject to its standard Conditions for the Supply of Goods and Services, copies of which may be obtained on request. Whilst Fosroc endeavours to ensure that any advice, recommendation, specification or information it may give is accurate and correct, it cannot, because it has no direct or continuous control over where or how its products are applied, accept any liability either directly or indirectly arising from the use of its products, whether or not in accordance with any advice, specification, recommendation or information given by it.

---

## SALES REPRESENTATIONS IN MAINLAND CHINA

Beijing · Changchun · Chengdu · Chongqing · Guangzhou · Shanghai · Shenzhen · Tianjin · Wuhan · Xiamen

For enquiries, please contact Fosroc Guangzhou office.

### Fosroc Guangzhou Limited

No. 7 Hong Yuan Road, Eastern Section, Guangzhou Economic & Technological Development District, Guangzhou, P.R.C. Post Code: 510760

Tel: +86 (20) 8226 9245

Fax: +86 (20) 8226 8010

email: [china@fosroc.com](mailto:china@fosroc.com)